

## Wireless 5V Pressure Sensor

### General Description

The Monnit wireless pressure sensor measures pressure from a 5 volt pressure transducer and transmits the pressure measurement to iMonnit. This solution combines a standard pressure transducer interfaced to a Monnit wireless radio.

- Measure pressure with 50 or 300 PSIG transducers (others available upon request).
- Measure non-caustic liquid or vapor pressures.
- Pressure transducer is NEMA 4X (IP66), CE rated.



Free iMonnit basic online wireless sensor monitoring and notification system to configure sensors, view data and set alerts via SMS text and email.

### Principle of Operation

By connecting the Monnit wireless pressure sensor to a pressurized gas, liquid or vapor supply line, it can measure the pressure within the line and send data to the iMonnit Online Sensor Monitoring and Notification System. The data is stored in the online system and can be reviewed and exported as a data sheet or graph. User customization allows you to set notifications and alerts from the system so you can know immediately if pressure is above or below an optimal range.

### Example Applications

- Compressors/Compressed Air Lines
- Water Supply Lines
- Pumping Systems
- Irrigations System Pressure
- Industrial Process Monitoring
- Trash Compaction Equipment

### Monnit Sensor Core Specifications

- Wireless Range: 250 - 300 ft. (non-line-of-sight / indoors / through walls, ceilings & floors) \*
- Communication: RF 900, 920, 868 and 433 MHz
- Power: Replaceable batteries (optimized for long battery life). Line-power (AA version) and solar (Industrial version) options available. Power ERP is 5,7mW
- Battery Life (at 1 hour heartbeat setting): \*\*
  - AA battery > 4-8 years
  - Industrial > 4-8 years

\* Actual range may vary depending on environment.

\*\* Battery life is determined by sensor reporting frequency and other variables.

### Sensor Types & Options

Wireless 5V Pressure Sensor (AA) 2

Wireless 5V Pressure Sensor (Industrial) 3

Options 4

## Wireless 5V Pressure Sensor (AA)

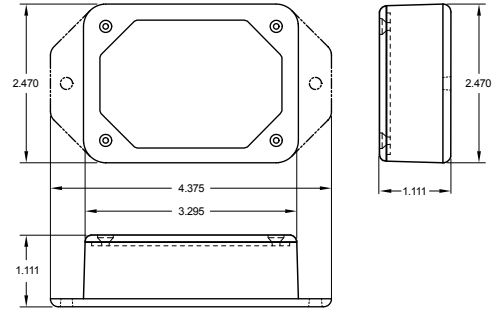

### Technical Specifications

Supply Voltage	2.0 - 3.6 VDC (3.0 - 3.6 VDC Using Power Supply) *
Current Consumption	0.7 $\mu$ A (sleep mode after measurement) 2 mA (radio idle/off mode) 2 mA (measurement mode) 25 mA (radio RX mode) 35 mA (radio TX mode)
Operating Temperature Range**	Using Alkaline AA Batteries: -18°C to +55°C (0°F to +130°F) Using Lithium AA Batteries: -40°C to +85°C (-40°F to +185°F)
Weight	10.3 oz.
Wireless Range	250 - 300 ft. (Through walls, ceilings and floors) Range may vary according to environmental variables.
Certifications	900 MHz product; FCC ID: ZTL- RFSC1 and IC: 9794A-RFSC1. 920 MHz product; ARIB STD-T108 R210-103733. 868 and 433 MHz product tested and found to comply with: CISPR 22:2008-09 / EN 55022:2010 - Class B and ETSI EN 300 220-2 V2.4.1 (2012-05).



### Pressure Transducer Technical Specifications

Operating Temperature	0 to 175°F (-18 to 79°C).
Thermal Effect on Reading	$\pm 0.02\%$ FS/°F. (includes zero and span).
Media	Gas, Liquid or Vapor
Response Time	50 msec.
Stability	1.0% FS/year (Typ.).
Wire Length	1 Meter shielded cable (between gauge and wireless unit)
Accuracy	0.25% FS; 0.20% RSS; Absolute Ranges: 0.5% FS; 0.35% RSS. (Includes linearity, hysteresis, and repeatability).
Max Voltage Input	5.5 V
Voltage Measurement Range	0 - 5.2 V ***
Voltage Measurement Resolution	$\sim 3$ mV
Voltage Measurement Accuracy	$\pm 3\%$ FS
Pressure Measurement Accuracy	$\pm 3\%$ FS
User Calibrated Pressure Accuracy	$\pm 1\%$ FS ****
Process Connection	$\frac{1}{4}$ " NPT-Male Standard
Pressure Transducer(s)	50 or 300 PSIG (Others available upon request)

#### Power Options

The standard version of this sensor is powered by two replaceable 1.5 V AA sized batteries (included with purchase).

This sensor is also available with a line power option. The line powered version of this sensor has a barrel power connector allowing it to be powered by a standard 3.0 - 3.6 V power supply. The line powered version also uses two standard 1.5 V AA batteries as backup for un-interrupted operation in the event of line power outage.

\* Hardware cannot withstand negative voltage. Please take care when connecting a power device.

\*\* At temperatures above 100°C, it is possible for the board circuitry to lose programmed memory.

\*\*\* The sensor is capable of measuring above 5 volts but may not meet the specified accuracy above this value.

\*\*\*\* For best results first zero the sensor then calibrate at greater than 20% maximum pressure of the transducer.

## Wireless 5V Pressure Sensor (Industrial)

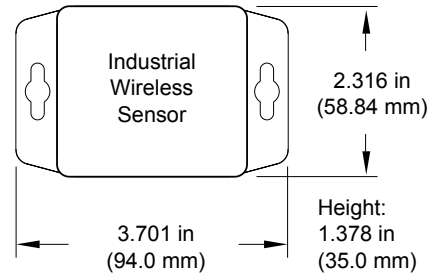

### Technical Specifications

Supply Voltage	2.0 - 3.6 VDC *	
Current Consumption	0.7 $\mu$ A (sleep mode) 2 mA (radio idle/off mode) 2 mA (measurement mode) 25 mA (radio RX mode) 35 mA (radio TX mode)	
Operating Temperature Range (Board Circuitry and Battery)		
Included Battery	Max Temperature Range:	-40°C to +85°C ( -40°F to +185°F ) **
	Capacity:	-40° to +85°C ( -40° to +185°F )
Optional Solar Feature	Solar Panel:	1800 mAh
	Charging Temperature Range:	5VDC / 30mA (53mm x 30mm)
	Max Temperature Range:	0° to 45°C (32° to 113°F)
	Included Rechargeable Battery:	-20° to 60°C (-4° to 140°F)
Enclosure Rating	NEMA 1, 2, 4, 4x, 12 and 13 rated, sealed and weather proof	
UL Rating	UL Listed to UL508-4x specifications (File E194432)	
Weight	13.3 oz	
Wireless Range	250 - 300 ft. (Through walls, ceilings and floors) Range may vary according to environmental variables.	
Certifications	900 MHz product; FCC ID: ZTL- RFSC1 and IC: 9794A-RFSC1. 920 MHz product; ARIB STD-T108 R210-103733. 868 and 433 MHz product tested and found to comply with: CISPR 22:2008-09 / EN 55022:2010 - Class B and ETSI EN 300 220-2 V2.4.1 (2012-05).	

### Pressure Transducer Technical Specifications

Operating Temperature	0 to 175°F (-18 to 79°C).
Thermal Effect on Reading	$\pm 0.02\%$ FS/°F. (includes zero and span).
Media	Gas, Liquid or Vapor
Response Time	50 msec.
Stability	1.0% FS/year (Typ.).
Wire Length	1 Meter shielded cable (between gauge and wireless unit)
Accuracy	0.25% FS; 0.20% RSS; Absolute Ranges: 0.5% FS; 0.35% RSS. (Includes linearity, hysteresis, and repeatability).
Max Voltage Input	5.5 V
Voltage Measurement Range	0 - 5.2 V ***
Voltage Measurement Resolution	$\sim 3$ mV
Voltage Measurement Accuracy	$\pm 3\%$ FS
Pressure Measurement Accuracy	$\pm 3\%$ FS
User Calibrated Pressure Accuracy	+/- 1% FS ****
Process Connection	1/4" NPT-Male Standard
Pressure Transducer(s)	50 or 300 PSIG (Others available upon request)

#### Solar Power Option



Monnit Industrial Sensors are powered by a replaceable 3.6V Lithium battery (included). An optional solar powered version is also available.

The solar powered sensor uses a Lithium Iron Phosphate rechargeable battery in conjunction with a solar power cell to extend battery life.

- \* Hardware cannot withstand negative voltage. Please take care when connecting a power device.
- \*\* At temperatures above 100°C, it is possible for the board circuitry to lose programmed memory.
- \*\*\* The sensor is capable of measuring above 5 volts but may not meet the specified accuracy above this value.
- \*\*\*\* For best results first zero the sensor then calibrate at greater than 20% maximum pressure of the transducer.

## Options

### Commercial Grade Sensors

Monnit commercial grade sensors are designed for applications in ordinary environments (normal room temperature, humidity and atmospheric pressure). Do not use these sensors under the following conditions as these factors can deteriorate the product characteristics and cause failures and burn-out.

- Corrosive gas or deoxidizing gas - chlorine gas, hydrogen sulfide gas, ammonia gas, sulfuric acid gas, nitric oxides gas, etc.).
- Volatile or flammable gas.
- Dusty conditions.
- Under low or high pressure.
- Wet or excessively humid locations.
- Places with salt water, oils chemical liquids or organic solvents.
- Where there are excessively strong vibrations.
- Other places where similar hazardous conditions exist.

Use these products within the specified temperature range. Higher temperature may cause deterioration of the characteristics or the material quality.

### Industrial Grade Sensors - Type 1, 2, 4, 4X, 12 and 13 NEMA Rated Enclosure

Monnit's Industrial sensors are enclosed in reliable, weatherproof NEMA rated enclosures. Our NEMA rated enclosures are constructed for both indoor or outdoor use and protect the sensor circuitry against the ingress of solid foreign objects like dust as well as the damaging effects of water (rain, sleet, snow, splashing water, and hose directed water).

- Safe from falling dirt.
- Protects against wind-blown dust.
- Protects against rain, sleet, snow, splashing water, and hose directed water
- Increased level of corrosion resistance
- Will remain undamaged by ice formation on the enclosure



For more information about our products or to place an order, please contact our sales department at 801-561-5555.

Visit us on the web at [www.monnit.com](http://www.monnit.com).

Monnit Corporation  
3400 South West Temple  
South Salt Lake, UT 84115  
801-561-5555  
[www.monnit.com](http://www.monnit.com)